

Bäckerei mit Zubehör

Bakery with Accessories
Boulangerie avec Accessoires
Bakkerij met Toebehoren

POLA G

Art. Nr. 331017/1

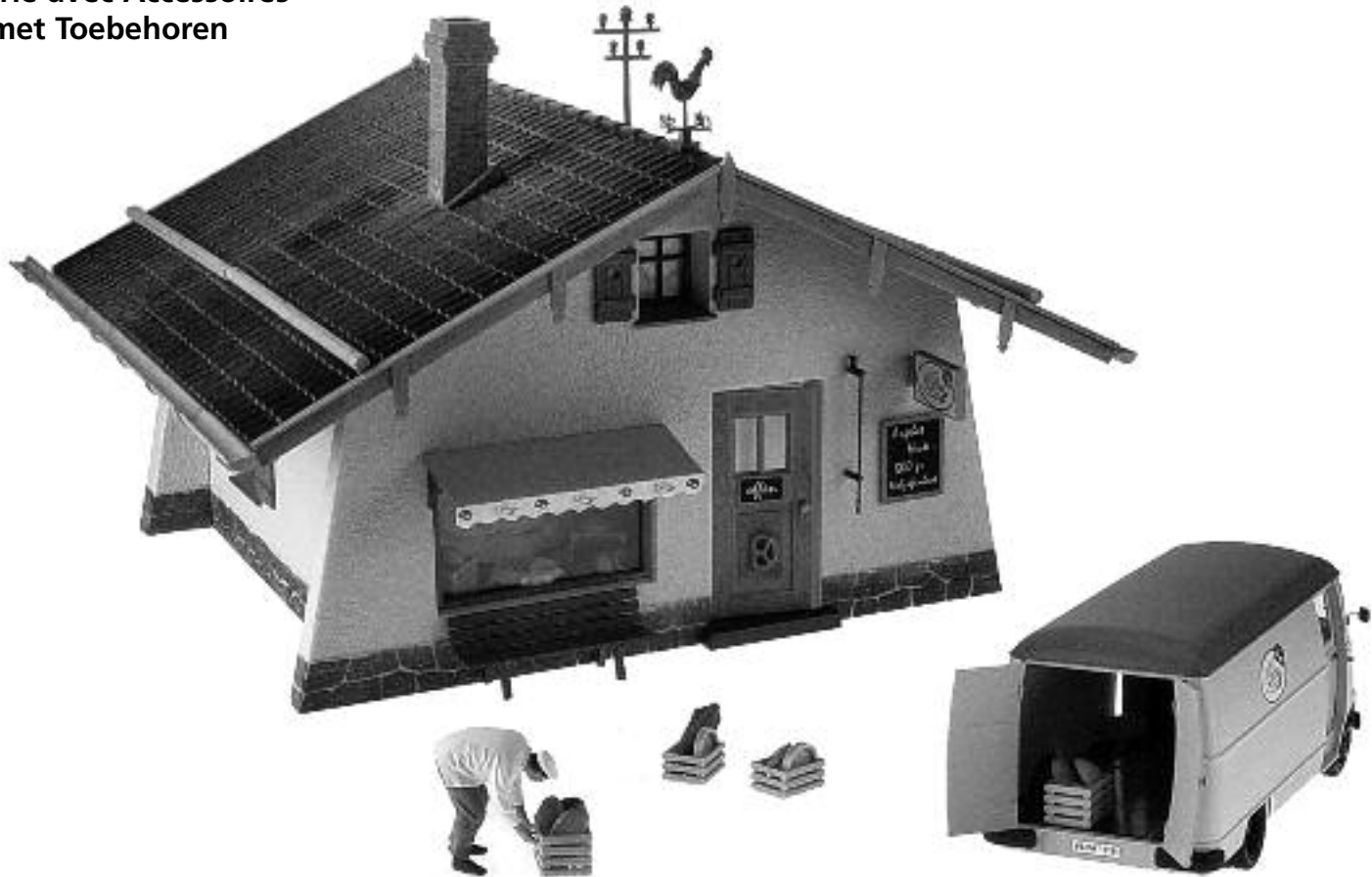

Sa. Nr. 410 475 0

- (D)**
- Verwenden Sie nur POLA G-Cement.
 - Machen Sie sich vor dem Zusammenbau gut mit den Einzelteilen des Bausatzes vertraut. Trennen Sie die Einzelteile erst dann ab, wenn sie gebraucht werden.
 - Verwenden Sie beim Zusammenbau wenig Klebstoff. Sie werden dann mehr Freude an einem sauberen Modell haben.
 - Sollte trotz werkseitiger sorgfältiger Prüfung ein Teil fehlen oder fehlerhaft sein, kreuzen Sie bitte das Teil in der Anleitung an und schicken Sie diese bitte an:
Gebr. FALLER GmbH, Abt. Kundendienst, kundendienst@faller.de, Kreuzstraße 9, D-78148 Gütenbach.
Sie erhalten dann umgehend Ersatz.

- Use POLA G-Cement only.
- (GB)**
- Familiarize yourself well with the components of the kit before assembly.
 - Do not break off the components until the moment you need them. Use glue sparingly on assembly, then you will enjoy your neat model even more.
 - If a part is missing or defective despite careful checking at the factory, please mark the part concerned in your instructions and send it to:
Gebr. FALLER GmbH, Abt. Kundendienst, kundendienst@faller.de, Kreuzstraße 9, D-78148 Gütenbach, Germany.
You will receive replacement promptly.

- N'utilisez que la colle POLA G -Cement.
- (F)**
- Avant l'assemblage, familiarisez vous avec les différentes pièces du jeu de construction.
 - Ne séparer les pièces particulières qu'au moment de les utiliser. Utiliser aussi peu de colle que possible pour l'assemblage, vous aurez d'autant plus de plaisir avec un modèle propre.
 - Si, malgré un contrôle soigneux à l'usine, une pièce devait manquer ou être défectueuse, marquer cette pièce d'une croix dans les instructions et envoyer ces dernières à:
Gebr. FALLER GmbH, Abt. Kundendienst, kundendienst@faller.de, Kreuzstraße 9, D-78148 Gütenbach (R.F.A.).
On vous la remplacera aussitôt.

- (NL)**
- Gebruik uitsluitend POLA G -cement.
 - Zorg da u vóór de montage goed weet uit welke onderdelen het bouw pakket bestaat. Maak de onderdelen pas los als u ze gaat gebruiken.
 - Gebruik bij de montage slechts weinig lijm. U zult dan meer plezier beleven aan een schoon model.
 - Mist u ondanks zorgvuldige fabrikantencontrole toch een onderdeel of is een onderdeel beschadigd, kruis dan het desbetreffende onderdeel aan in de handleiding en stuur dit s.v.p. aan:
Gebr. FALLER GmbH, Abt. Kundendienst, kundendienst@faller.de, Kreuzstraße 9, D-78148 Gütenbach, Duitsland.
Het wordt dan direct vervangen en naar u opgestuurd.



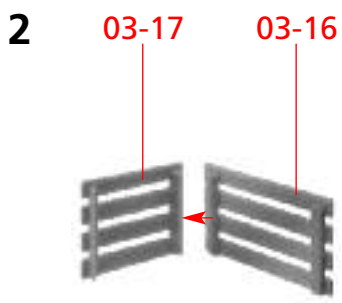

(A) 3 x

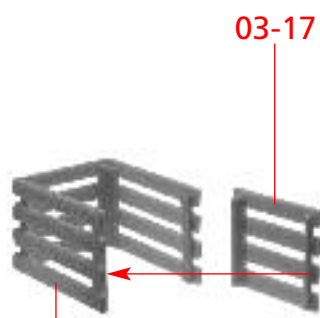

03-16

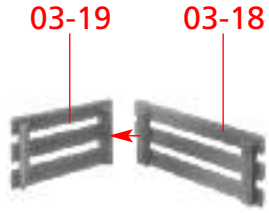
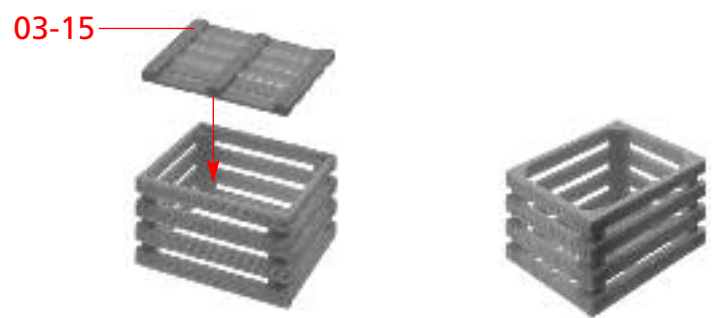

(B) 3 x

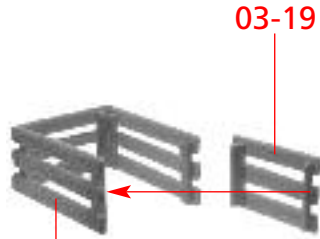

03-18

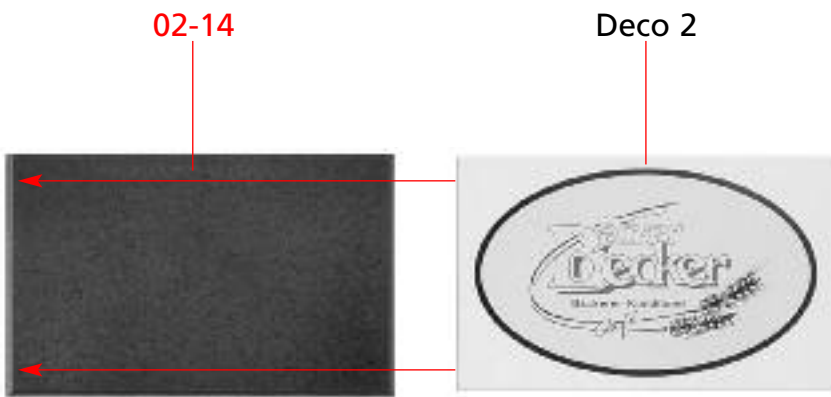
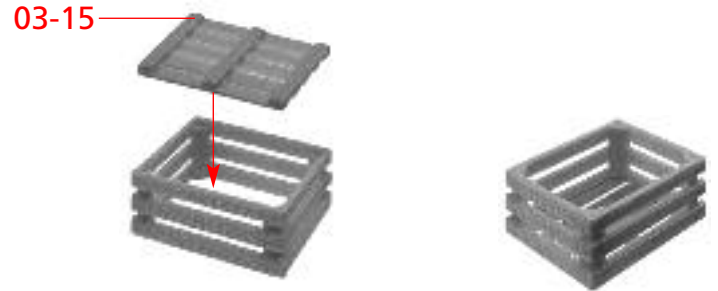

(C)

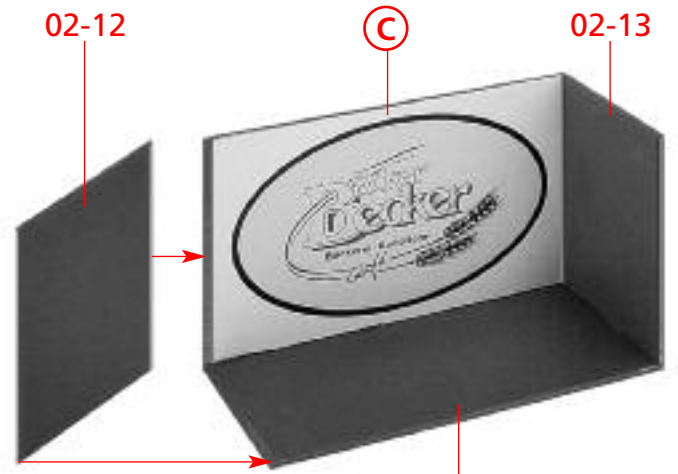

(D)



02-16

(E)

heraustrennen
rip out
retirer
eruit nemen

5

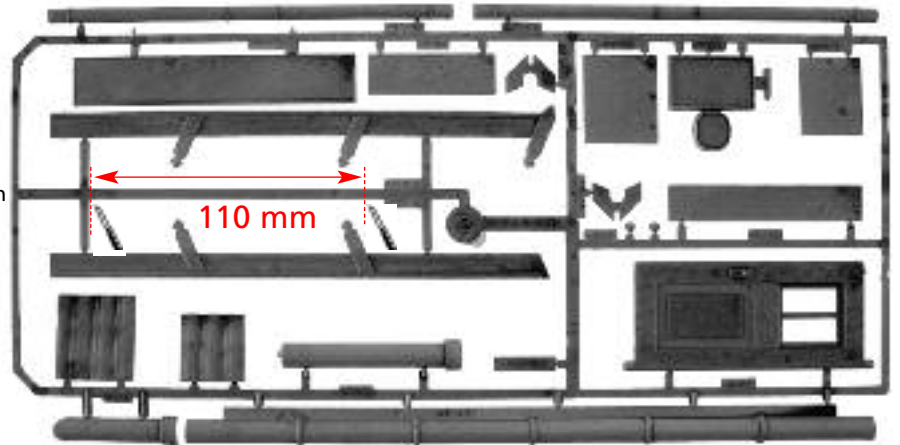

Faden verknoten und den Knoten mit Sekundenkleber fixieren!
Knot the thread and fix the thread with instand cement!
Noier le fil et renforcer le noed avec une goutte de colle rapide!
Draad vastknopen en de knoop met secondenlijm fixeren!

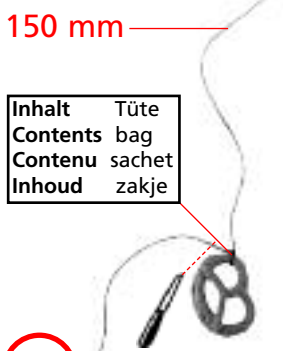

(F)

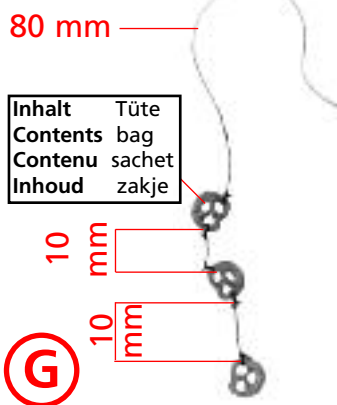

(G)



(H)

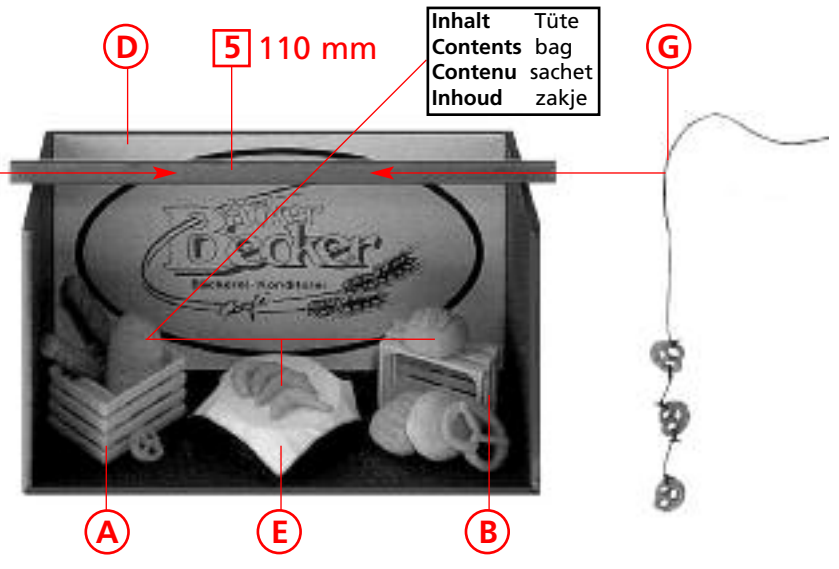

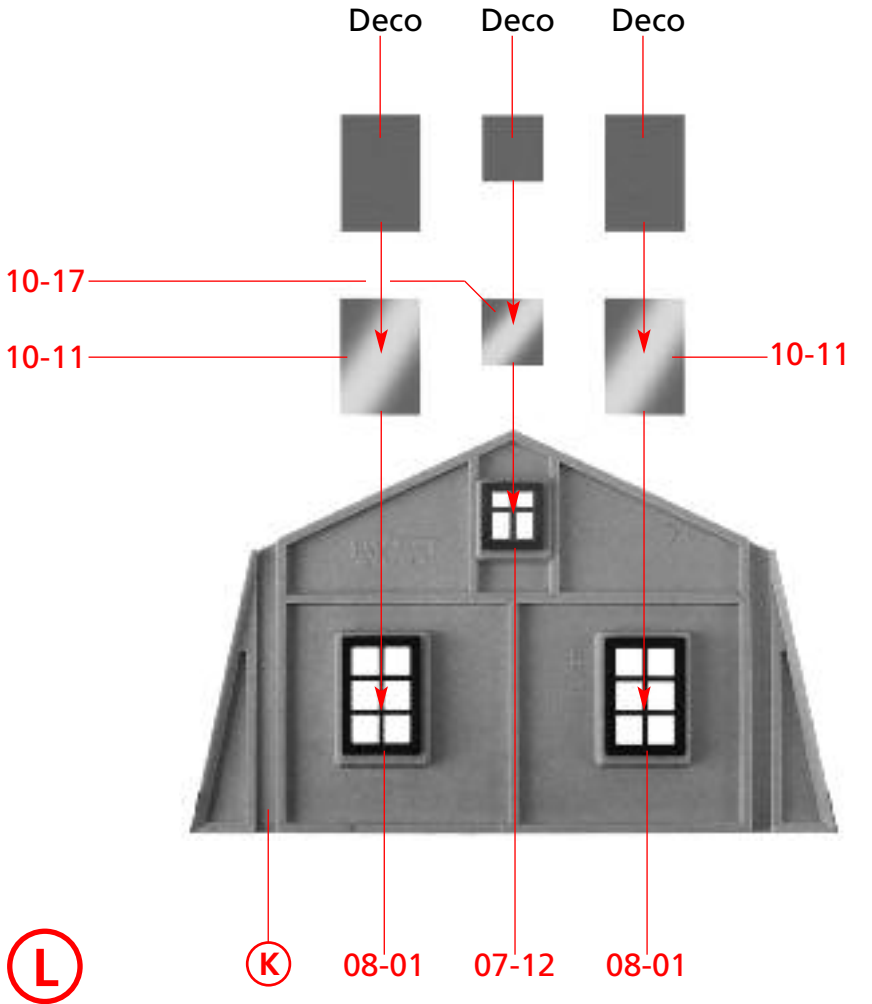
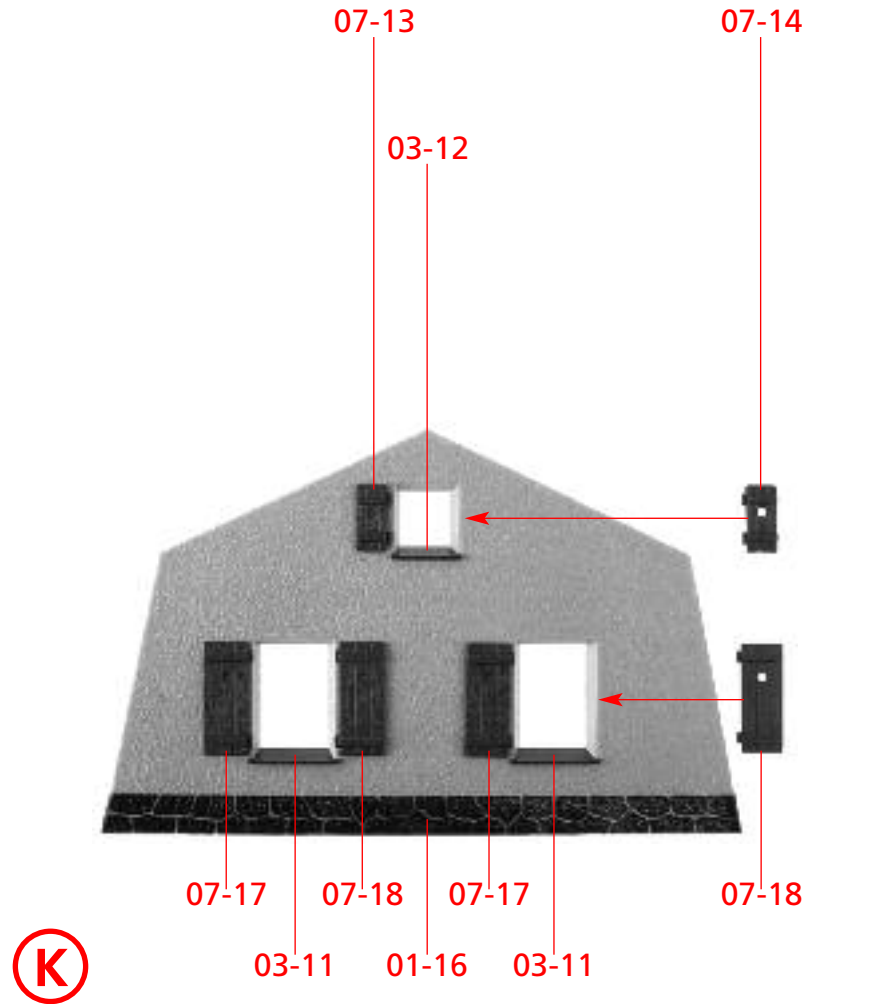
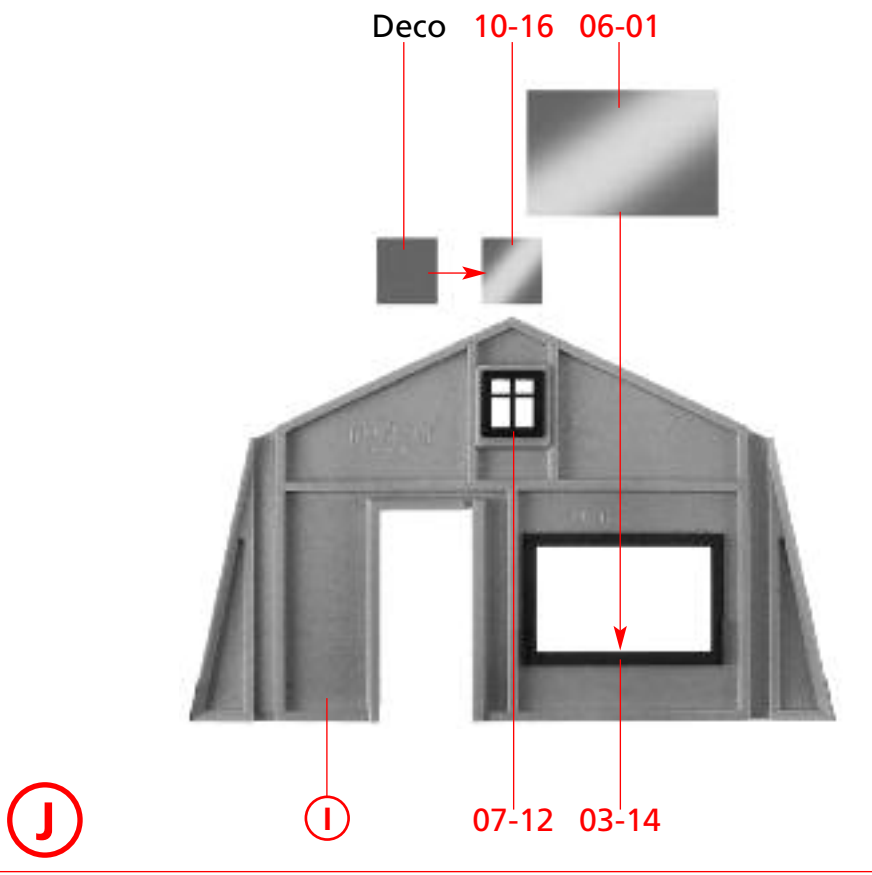
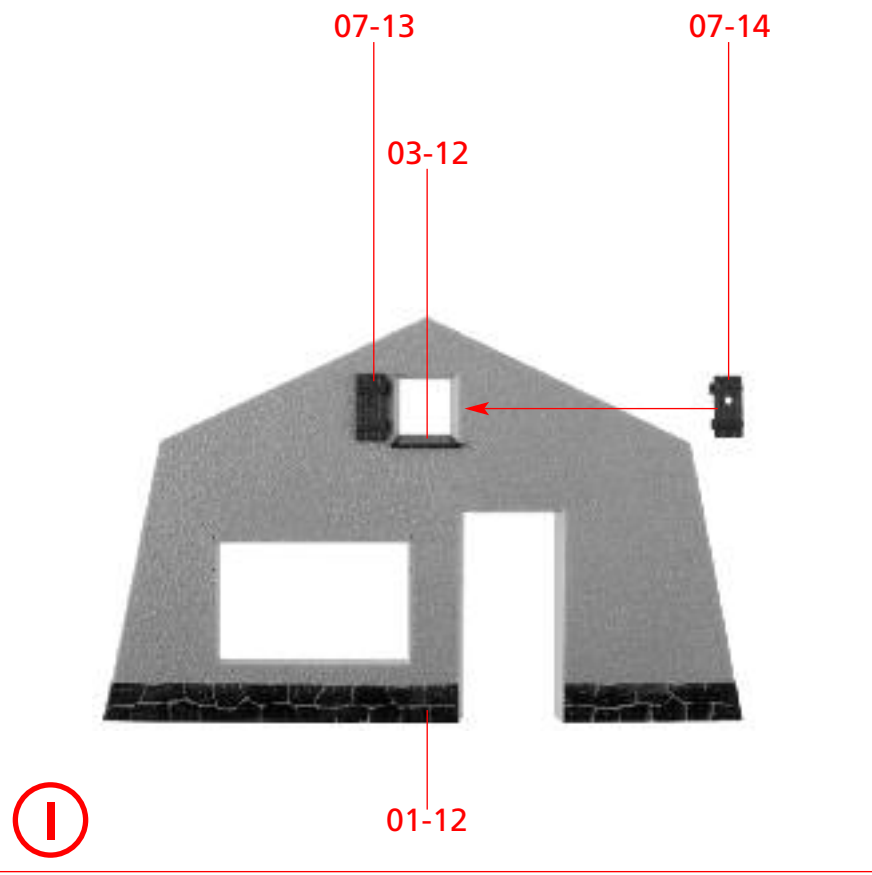
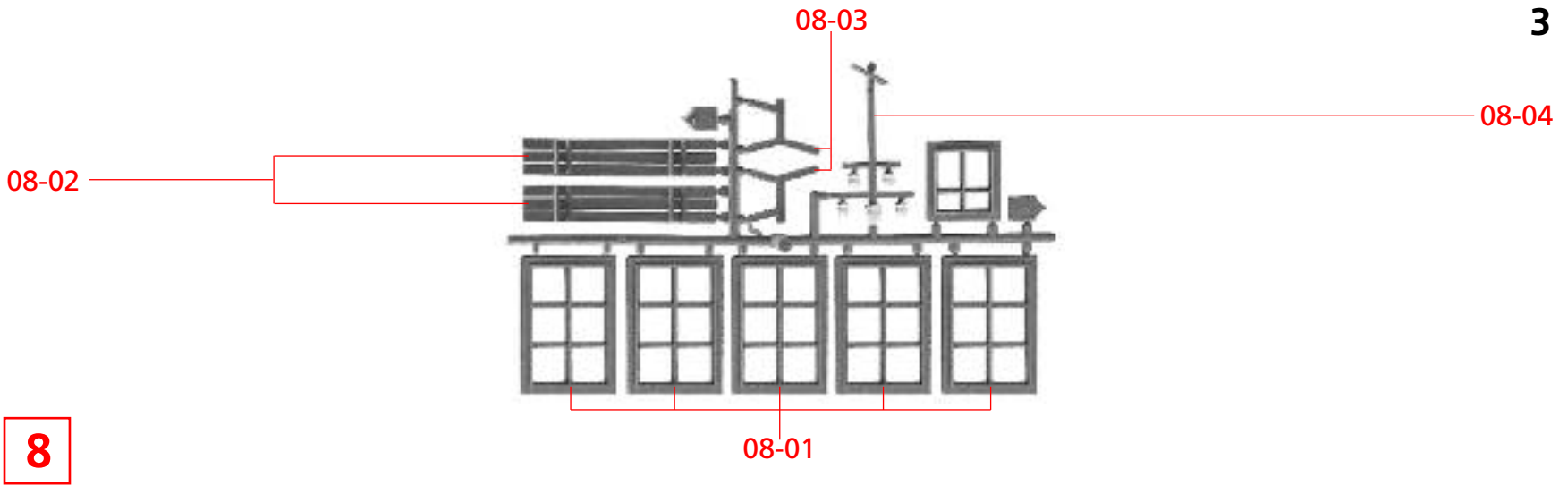

4

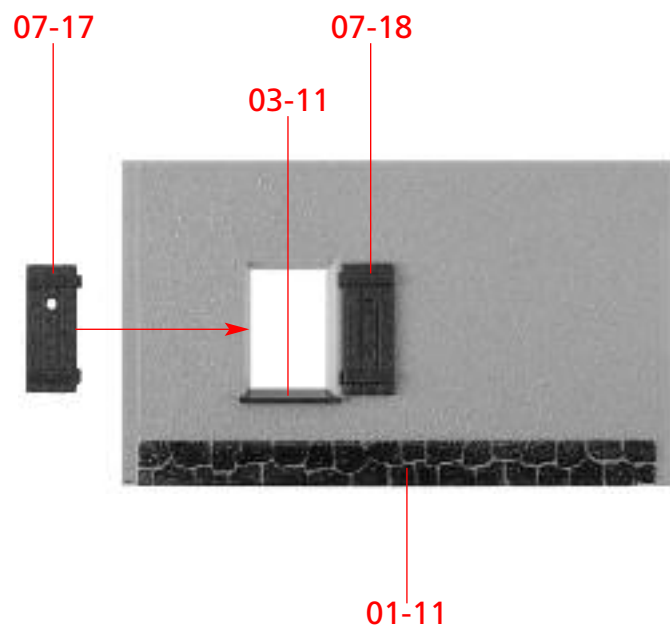

M 2 x

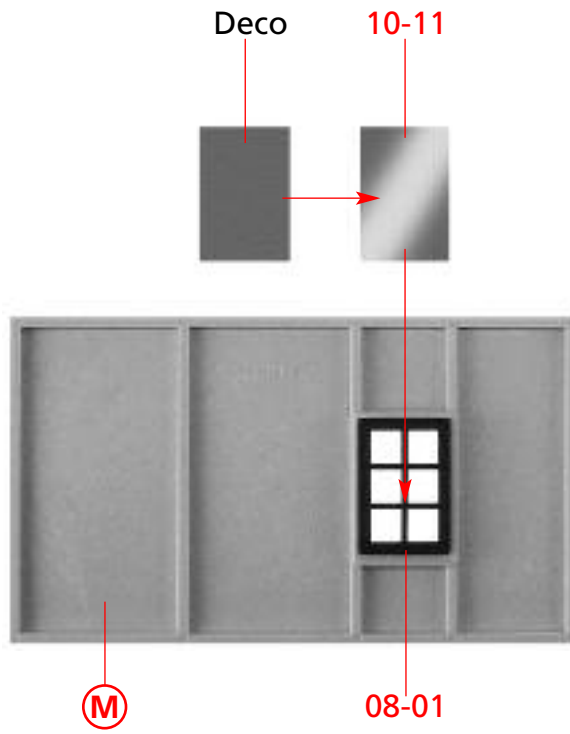

N 2 x

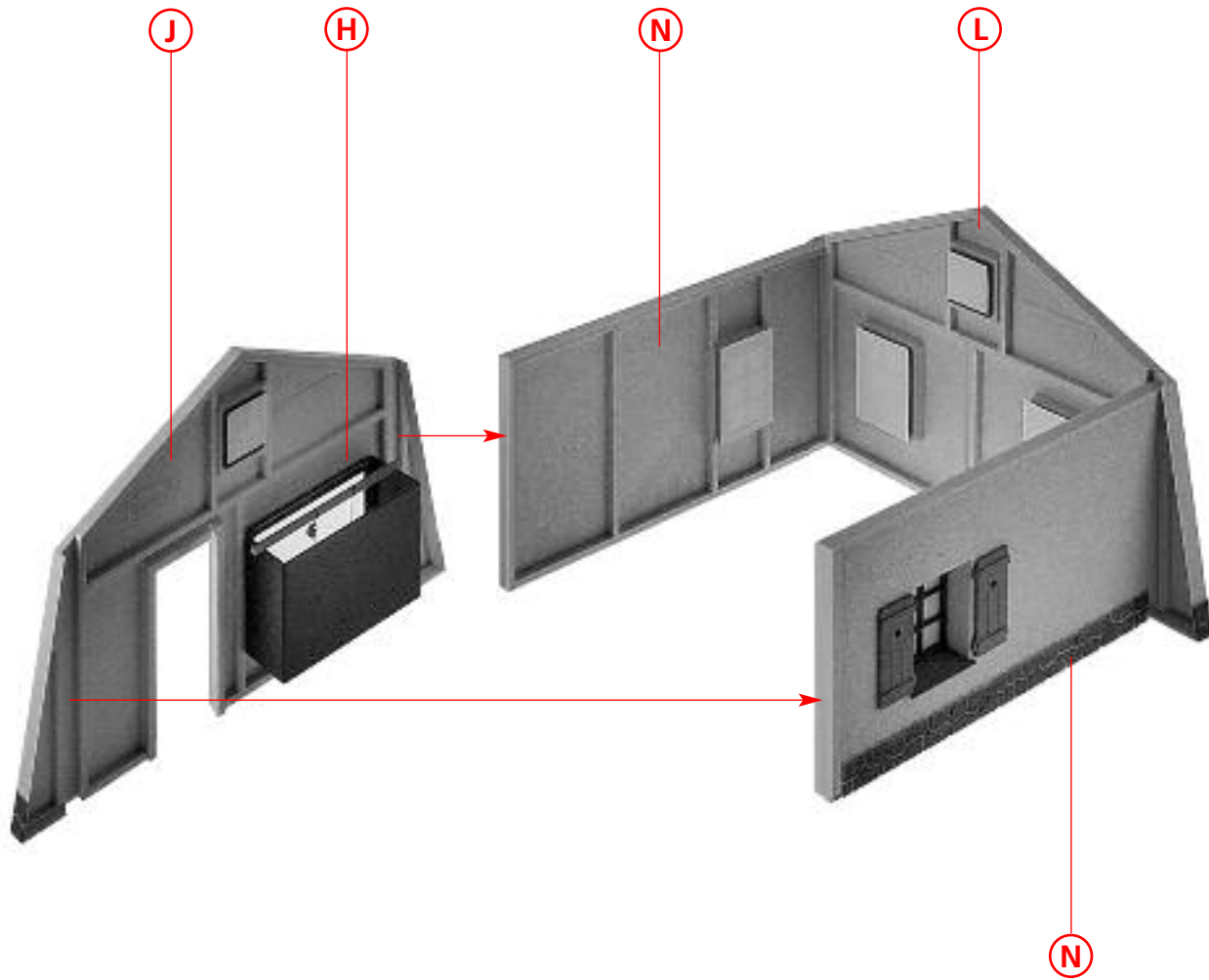

O

N

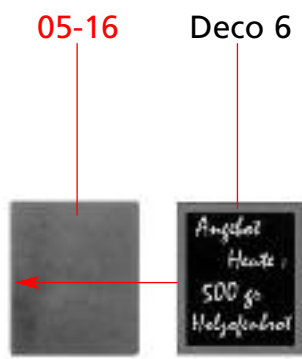

P

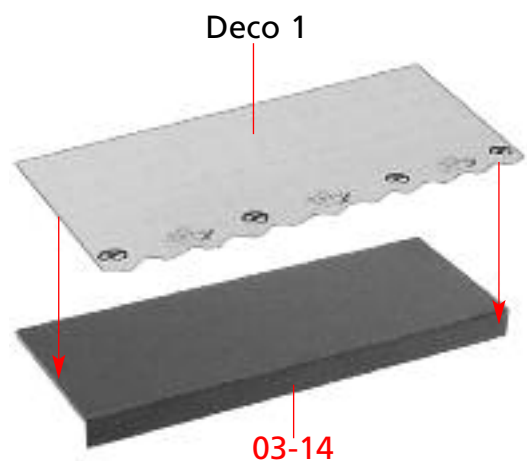

Q

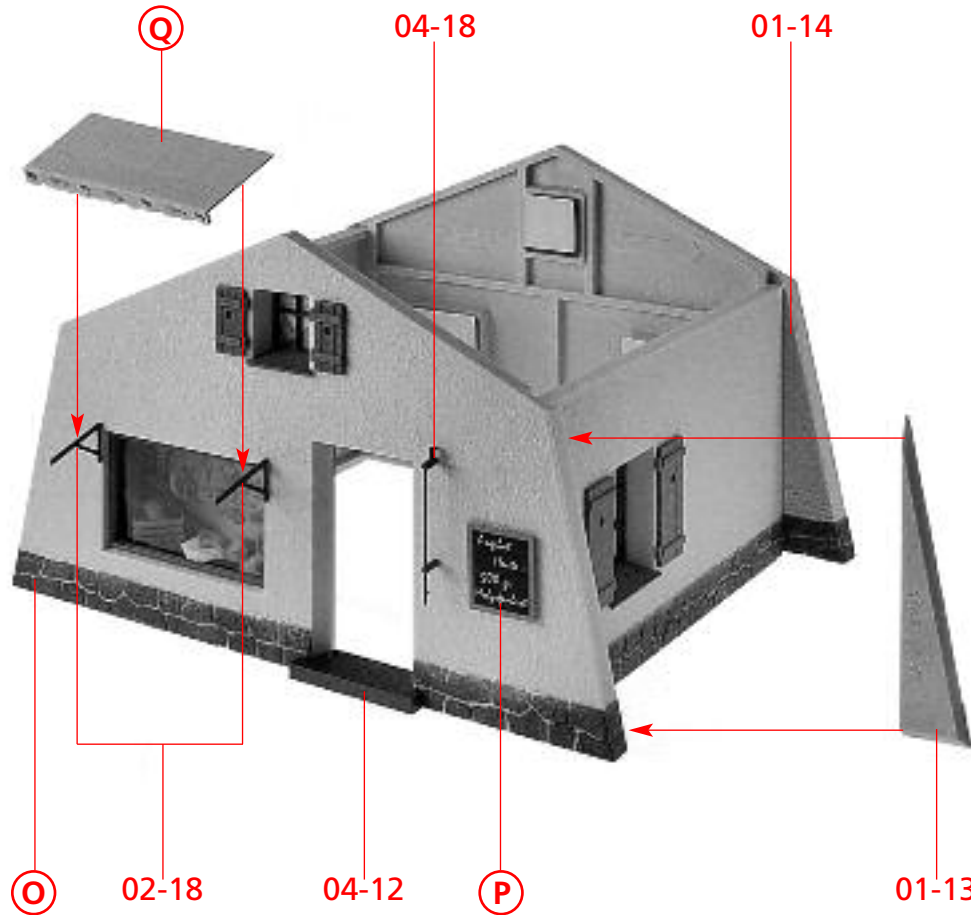

R

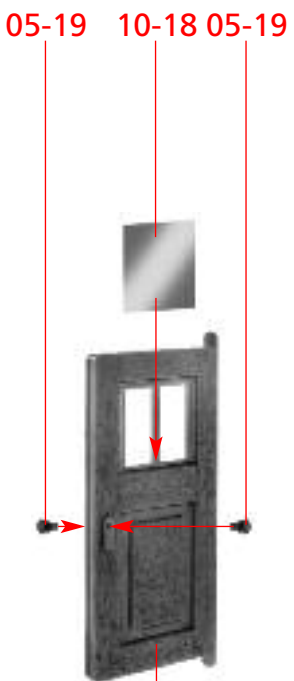

S

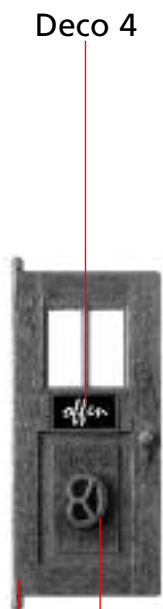

T

S

Inhalt	Tüte
Contents	bag
Contenu	sachet
Inhoud	zakje

U

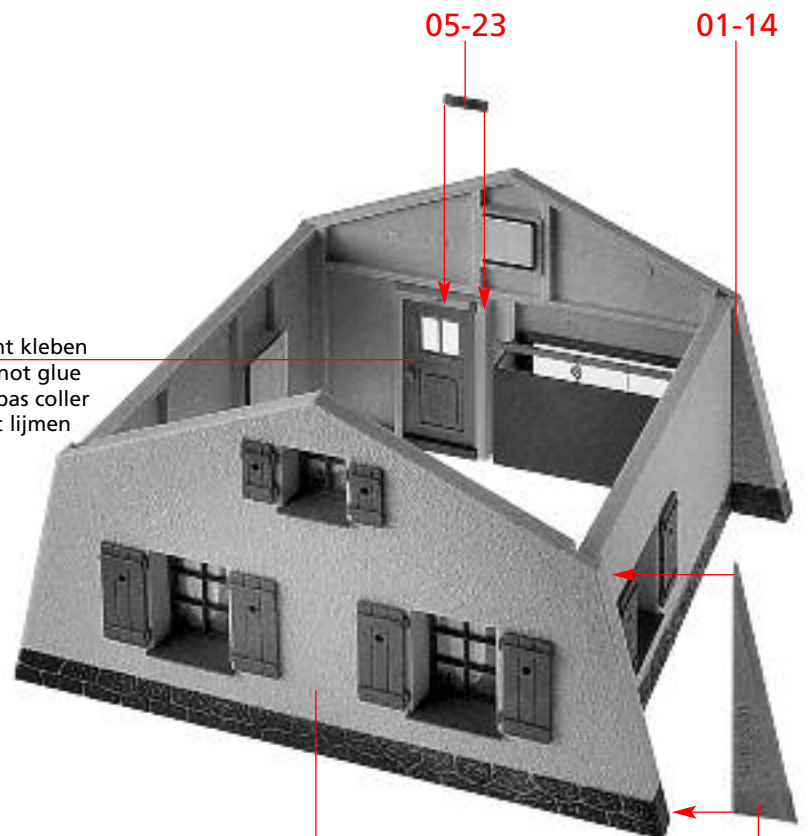

T nicht kleben
do not glue
ne pas coller
niet lijmen

R

01-13

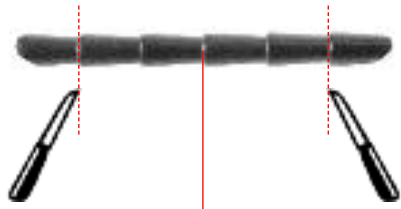

(V)

-41

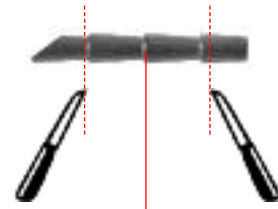

(W)

-40



(X)

05-11

05-13

05-12

03-11

(W)

-68

(V)

03-11

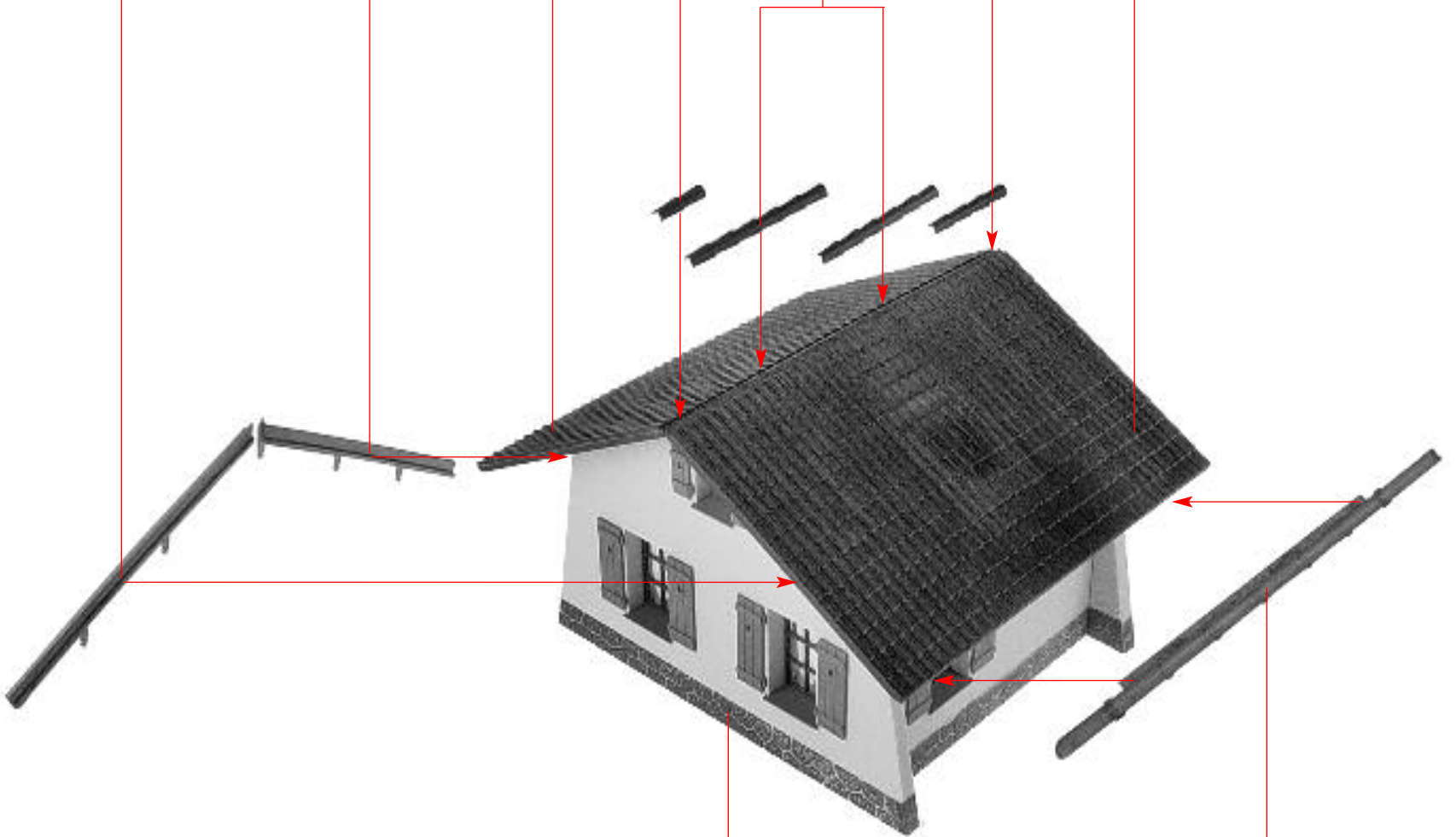

(Y)

(U)

(X)

Deco 3
Inhalt Tüte
Contents bag
Contenu sachet
Inhoud zakje

Deco 3
Inhalt Tüte
Contents bag
Contenu sachet
Inhoud zakje

(a)

05-17

(b)

(a)

(c)

05-12 05-11

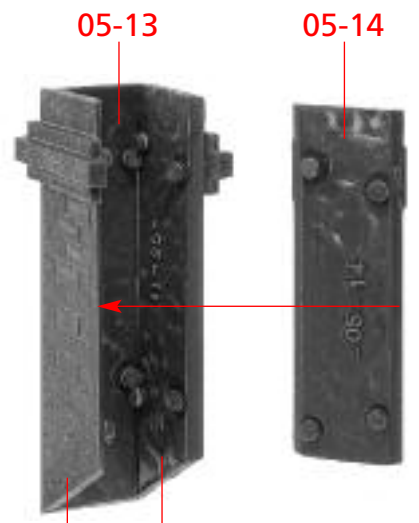

(d)

04-20

(e)

04-13

(f)

04-15

04-16

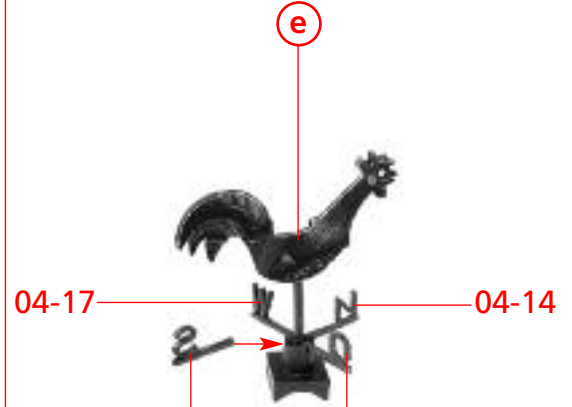
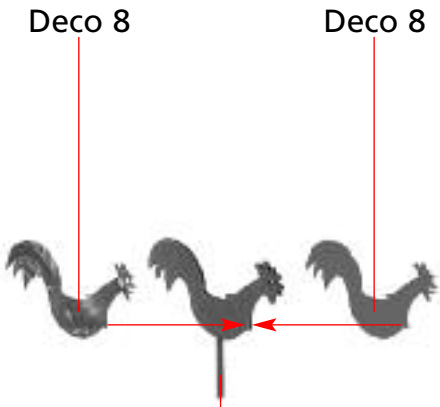

(g)

05-11



04-11

05-14

(h)

05-12

(Y)

05-13

05-14 (c)

(f)

08-04

05-14

(g)

05-14

(b)

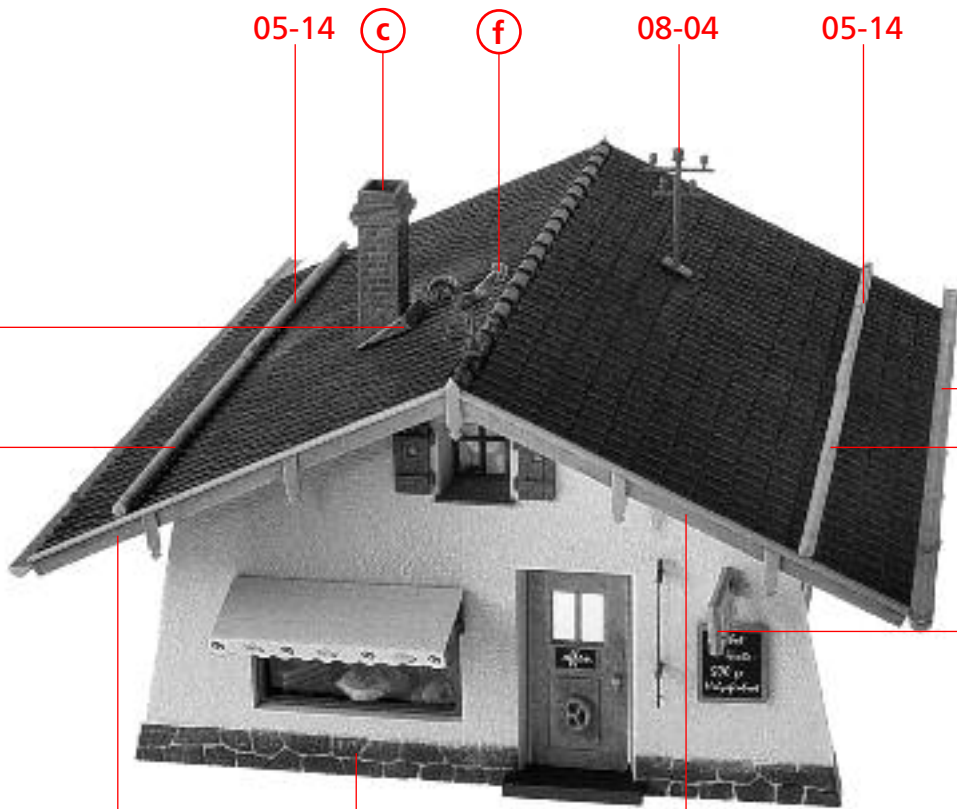

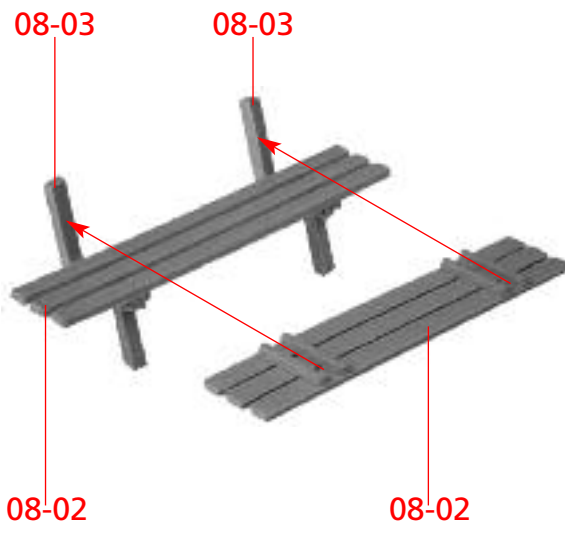

Art. Nr. 331017/2

Deco 7



Deco 7

Art. Nr. 331017/2

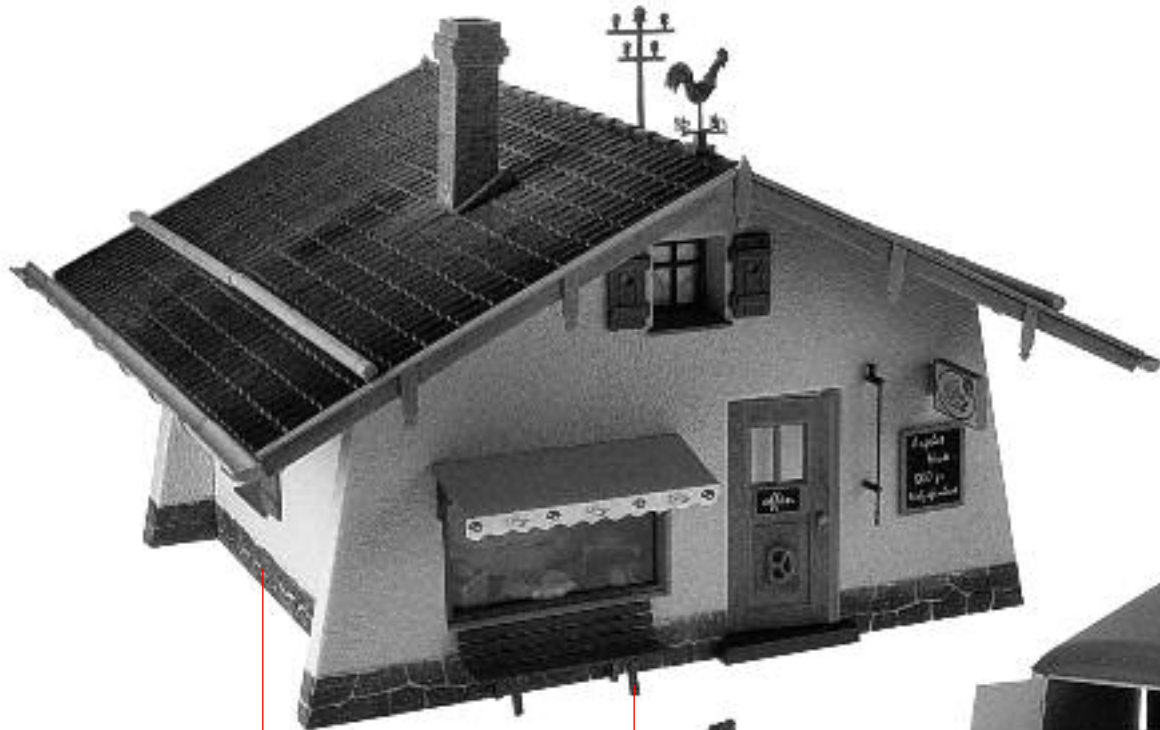

Inhalt	Tüte
Contents	bag
Contenu	sachet
Inhoud	zakje

